

Class 5000 Meter

ADVANCED KWH/DEMAND METER

INSTALLATION INSTRUCTIONS



E-Mon
850 Town Center Drive
Langhorne, PA 19047
(800) 334-3666
www.emon.com
info@emon.com



CLASS 5000 METER

Dear Valued Customer,

We are pleased that you chose to buy one of our products, and want you to be just as pleased with owning it. Before installing your new E-Mon product, please read the information on the following pages carefully.

We believe that you will find the E-Mon D-Mon meters easy to install and to use for monitoring and evaluating your electrical usage.

To be sure that you are 100% satisfied with your products, we provide toll-free technical and sales support Monday through Friday, 8:00 am to 7:30 pm, EST: (800) 334-3666. You may also reach us via email at info@emon.com.

If you have questions, we can handle them quickly and effectively with a telephone call. Please let us try to help you BEFORE you remove your meter. And to help us help you, we ask that you have all relevant information on hand when you call (model or part numbers, nature of difficulty, etc.)

Be sure to forward this manual to the owner after installation is complete, so that they may use it as a reference guide when reading the E-Mon D-Mon meter.

Thank you.

TABLE OF CONTENTS

Section 1.0	Introduction	4
Section 2.0	Internal Electronic Assemblies	5
Section 2.1	Main Power Board	6
Section 2.2	Display Board	7
Section 2.3	Input Board	8
Section 2.4	Pulse Type and Value	9
Section 3.0	Meter Technical Specifications	9
Section 4.0	Safety Label Definitions and Information	12
Section 5.0	Precautionary/Safety Information	12
Section 6.0	Meter Installation	13
Section 6.1	Mounting the Class 5000 Meter	13
Section 6.2	Main Power Board Connections	13
Section 6.3	Phasing of Line Voltage	15
Section 6.4	Current Sensor Installation & Wiring	16
Section 6.5	Main Power & Current Sensor Wiring Diagram	19
Section 6.6	Line Voltage/Current Sensor Diagnostics	19
Section 6.7	RS-485 Wiring	21
Section 6.8	RS-232 Communications	23
Section 6.9	Modem Wiring	25
Section 6.10	Modbus RTU Wiring	29
Section 6.11	BACnet Wiring	29
Section 6.12	Connecting Class 5000 Meters to USB Key using RS485	30
Section 6.13	Ethernet Communications	31
Section 7.0	Multiple-Load Monitoring	32
Section 8.0	Preventative/Scheduled Maintenance	33
Section 9.0	Lithium Battery Replacement	35
Section 10.0	Class 5000 Meter Features	35
Section 10.1	Display Board Push Buttons	36
Section 10.2	Normal Mode Display Screens	37
Section 10.3	How to Program the Display Screens	43
Section 11.0	Frequently Asked Questions	45
Section 12.0	Protocol Descriptions	55
Section 13.0	High Voltage Metering	58
Section 14.0	Meter Limited Warranty	59

1.0 INTRODUCTION

The E-Mon D-Mon® Class 5000 meter is a 3-phase meter with communications. The device is used to monitor electric power usage of individual loads after the utility meter and store kW and kVAR data for automatic meter reading. The Class 5000 meter is dual protocol capable and provides both RS485 and Ethernet communications. Installation must only be performed by qualified personnel and in accordance with these instructions and all applicable local and national electrical codes. E-Mon and its representatives assume no responsibility for damages or injury resulting from the improper installation of this meter.

Verify the input voltage rating and configuration on the unit panel label to ensure that it is suitable for the intended electrical service. Class 5000 meters labeled for 120/208V service **MUST NOT** be installed on service feeds of 277/480 volts or 347/600 and vice versa. Verify that the Class 5000 meter's current sensors are sized suitably for the load to be monitored. Compare the color of the arrows on the current sensors to the chart below to confirm the correct current sensor is being used.

Sensor Arrow Color Code	Sensor Rating
Brown	100 A
Red	200 A
Yellow	400 A
Black	800 A
Blue	1600 A
White/Black	3200 A



CAUTION

Internal circuit card components are extremely sensitive to electrostatic discharge. Prior to handling or touching internal circuitry, discharge any static buildup on your person. To discharge yourself, touch a grounded metal object such as conduit or an earth grounded metal enclosure.



WARNING

Use of this instrument, Class 5000, in a manner inconsistent with this manual or not specified by the manufacturer in writing, can cause permanent damage to the unit and/or serious injury to the operator. The protection and safety features provided by this equipment may become impaired or otherwise compromised.

NOTE: If any trouble arises during installation or functional verification operations, do not immediately remove unit. Before removing the unit, contact E-Mon's technical support department at (800) 334-3666. E-Mon's technical department will assist you in detailed troubleshooting of the Class 5000 installation.

2.0 INTERNAL ELECTRONIC ASSEMBLIES

The unit is comprised of two major subassembly boards, the main power board and the display board. Both circuit boards are mounted inside a NEMA 4X enclosure.

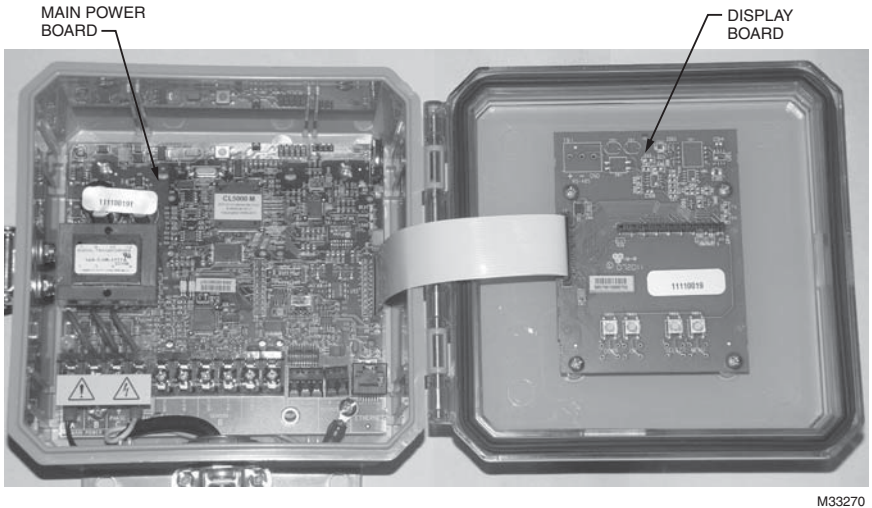

Fig. 1. Internal Electronic Assemblies.

2.1 Main Power Board

Connections to this board include the MAIN Power Input and current sensors. The MAIN Power Input terminals are positions one through four on the four position screw terminal block, TB1. These terminals are covered with a protective shield for safety purposes. The current sensor assemblies interface to the TB2, TB3 and TB4. Each terminal block corresponds to an input voltage phase; care must be exercised to ensure that each current sensor is connected to the correct terminal block. One three terminal screw connector(TB42) is provided for RS-485 communications. One RJ-45 jack (J8) is provided for 10/100-base T Ethernet.

The contact is a solid-state switch for the phase-loss alarm function. Switching is limited to 100 ma (0.1 amp) and voltage should not exceed 60 Volts AC or DC.

The (N.O.) contact closes within the meter due to the loss any one of the three lines of voltage inputs to the meter. The contact closure may be used to activate an audible alarm, light, control coil, or other indicator device. This alerts appropriate personnel to the loss of voltage. An emergency phone dialer may also be programmed to send notification automatically by phone, text, or pager. Alarming devices to be supplied by others and are not included by with the E-Mon Class 5000 meter.

One two terminal screw connector provides phase loss alarming.

There are also two headers present for adding option cards. Header J3 is 20 positions for use with an I/O board with up to two relays, two pulse inputs and two pulse out puts. Header J4 is a 10 positions for use with modem and LonWorks TP/FT-10.

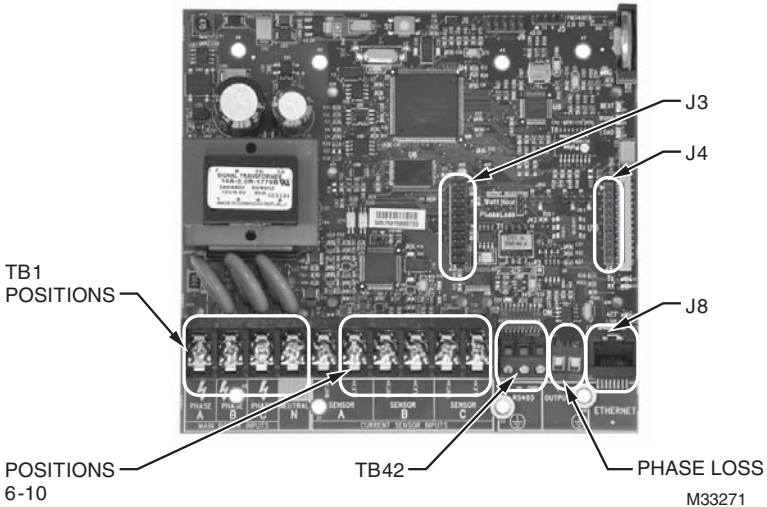

Fig. 2. Main Power Board.

2.2 Display Board

The display board connects to the main power board via a flex ribbon cable and the board mounts on the inside of the housing door.

No additional connections to the display board are required. The display board's LCD readout indicates the metered values as well as errors associated with the Class 5000 meter, such as phase loss or sensor error conditions.

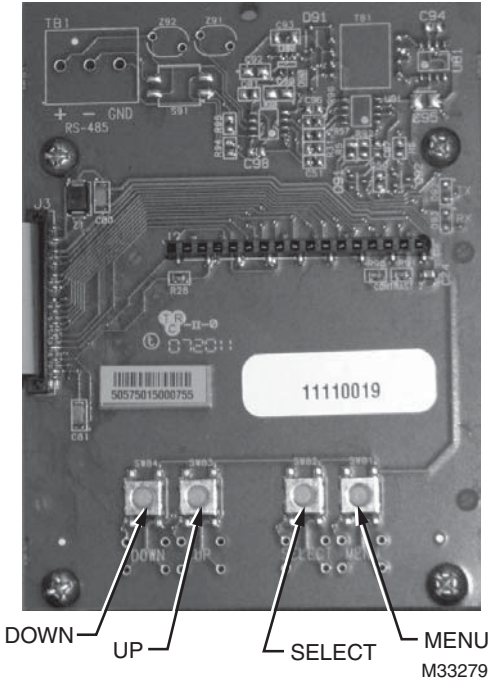
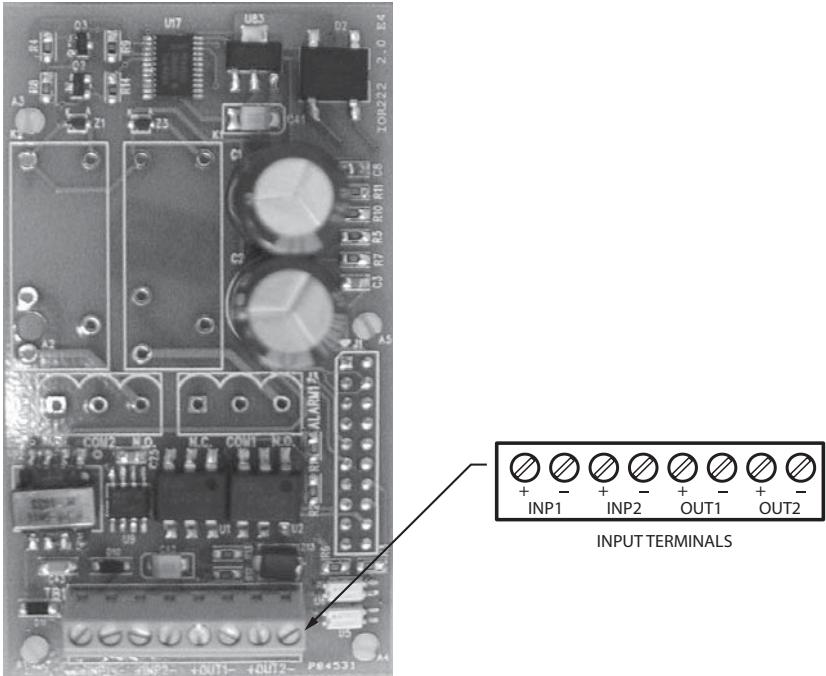

Fig. 3. Display Board.

2.3 Input Board

The Class 5000 meter is supplied with an input board which allows it to accept pulses (dry contact) from third party meters, such as gas, water, BTU, etc.



CL5000 METER INPUT BOARD

M33272

Fig. 4. Input Board.

The input terminals are used by the Class 5000 meter. The output terminals are not. Connect metering devices with “dry contacts” only. If the contacts are from solid - state (electronic) sources, polarity must be observed for proper operation.

2.4 Pulse Type and Value

The pulse outputs provided by the Class 5000 meter are watt-hours and var-hours. Output 1 is the watt-hour pulse and Output 2 is the var-hour pulse. The pulse value is dependant on the amperage size of the meter. See the chart below for the values also true for expansion board pulse output.

Meter Amps	Watt-hours / pulse	Var-hours / pulse
100	1.95313	1.95313
200	3.90625	3.90625
400	7.8125	7.8125
800	15.625	15.625
1800	31.25	31.25
3200	62.5	62.5

3.0 METER TECHNICAL SPECIFICATIONS

EXAMPLE:

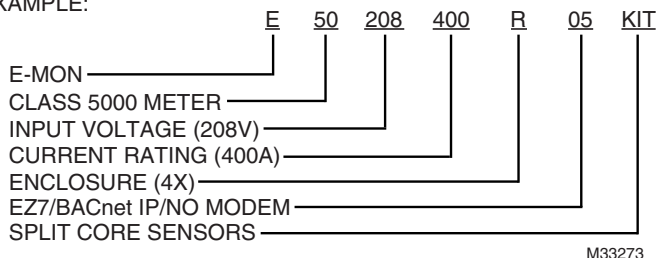

Ordering Information: Define brand, class, input voltage, current sensor rating, enclosure, protocols/options, expanded feature package, and sensor type in the format A-BB-CCC-DDDD-E-FF-G-HHH, where:

A = Brand: E for E-Mon

BB = designates Class: 3200 (32), 3400 (34), or 5000 (50) meter

CCC = input voltage: (208, 480, 600, 120 volt for high voltage applications only)

DDDD = current sensor rating: (100, 200, 400, 800, 1600, 3200, 25HV)

E = enclosure: J = metal (type 1), R = non-metallic (type 4X)

FF= protocol option:

G = Expanded Feature Package: package = X, no package = "blank"

(on Class 3400 only)

HHH= Sensor Type: kit=split-core, scs= solid-core, non-supplied blank"

"-SP" = 1 or 2 Phase

3.0 METER TECHNICAL SPECIFICATIONS (CONTINUED)

Input Voltage Configuration	3-wire (Delta) Or 4-wire (Wye)
Mains Voltage Input	Up To 480 VAC RMS Available
Input Power	6 VA Maximum Rating
Current Sensor Rating	Up To 3200 Amps RMS AC Available
Power Factor	0.5 Leading Or Lagging
Line Frequency	50-60 Hz
Metering Accuracy	Certified To ANSI C12.20
Voltage Operating Range	+/-10% Of Rated Load
Temperature Range	-20 C To +50 C (Standard indoor enclosure):
Temperature Range	-20 C To +70 CNEMA 4X (NEMA 4X outdoor enclosure)
Relative Humidity Range	0-95% Non-condensing
Altitude	2000 Meters Maximum
Voltage Overload	+25% Continuously: +100% For 20 Cycles
Current Sensor Overload	100% For 1 Minute Without Damaging Meter
Pollution Degree	Degree 2 In Accordance With IEC 664
Installation (Overvoltage) Category	Category 111
Measurement Category	Category 111
Enclosure Material	Indoor Housing Rating (Standard): NEMA 12 Outdoor Housing Rating (Optional): NEMA 4X
Display Readout	KWh Accumulated,
Standards	EN 61326-1:2006 IEC 61010-1:2001, 2nd Edition
Standard Ranges	4-Wire Wye, 120/208 VAC: 100, 200, 400, 800,1600,3200 Amp 2 Phase, 120/240 VAC: 100, 200, 400, 800,1600,3200 Amp 4-Wire Wye, 277/480 VAC: 100, 200, 400, 800,1600,3200 Amp 3-Wire Delta, 220/240 VAC: 100, 200,400,800,1600,3200 Amp 3-Wire Delta, 480 VAC: 100, 200, 400, 800,1600,3200 Amp

Modem Interface	Cable:	UL-listed Telephone Cord, 6-cond. 300 VAC, Stranded Cond. 22-26 AWG.
	Cable Connector:	RJ-45 male IDC
	Input/Output Voltage:	+5 VDC/18 VAC
	Ckt Input Isolation	5.3K VAC for 1 Minute
	Baud Rate:	9600
IDR Interface Port	Cable:	UL-listed/rated Telephone Cord. 4-cond.
	Input/output Voltage:	Ground-isolated +/-5.4VDC
	Cable Connector:	RF-45 Male IDC Or Screw Terminal Termination
	Circuit Input Isolation:	5.3kVAC
	Circuit output Isolation:	21.5kVAC
	Isolated Pulse/Alarm Outputs (TB5, TB6):	
	Output Voltage Potential:	0 VDC to +5 VDC Logic Levels
	Mating Plug Connector:	Weidmuller PN: 152876
Recommended In-line Fuse	Signal Isolation Voltage:	5.3K VAC for 1 Minute
	Manufacturer:	Littlefuse
	Mfg. Part No:	KLDR.100
Battery Cell	Rating:	100mA, Time-delay, 600VAC Cartridge Fuse
	Description:	Non-rechargeable Cell Used For Memory Retention
	Manufacturer:	Panasonic
	Mfg Part No:	CR2032
	Working Voltage:	3 VDC
	Current Capacity	225 mAHr
Electrolyte:	Manganese Dioxide Lithium	

4.0 SAFETY LABEL DEFINITIONS AND INFORMATION

The 5000 meter may contain one or more of the following labels. Operator(s) should familiarize themselves with the meaning of each label to minimize risk.



The presence of this label is a cautionary indicator identifying a danger risk. The manual should be consulted prior to proceeding.



The presence of this label indicates an electrical shock hazard exists in the location or area where the label is placed. Prior to proceeding, the MAINS power must be disconnected and the manual consulted for safety information.

5.0 PRECAUTIONARY AND SAFETY INFORMATION



CAUTION

Internal circuit card components are extremely sensitive to electrostatic discharge. Be careful not to touch internal circuitry prior to discharging any static buildup on your person. To discharge yourself, touch a grounded metal object such as conduit or an earth-grounded metal enclosure.



WARNING

High voltages present on main PCB terminal block TB1 screw terminals. Risk of serious injury and/or electrical shock exists. Prior to performing any wiring operations, review all contents of the user manual and de-energize the MAINS power switch. Only qualified personnel should perform installation wiring. Installation wiring must comply with all local and national electrical codes.



WARNING

NEVER open front panel of unit while unit has MAINS power applied. Failure to comply can increase the risk of serious injury and/or electrical shock.

6.0 METER INSTALLATION

6.1 Mounting the Class 5000 Meter

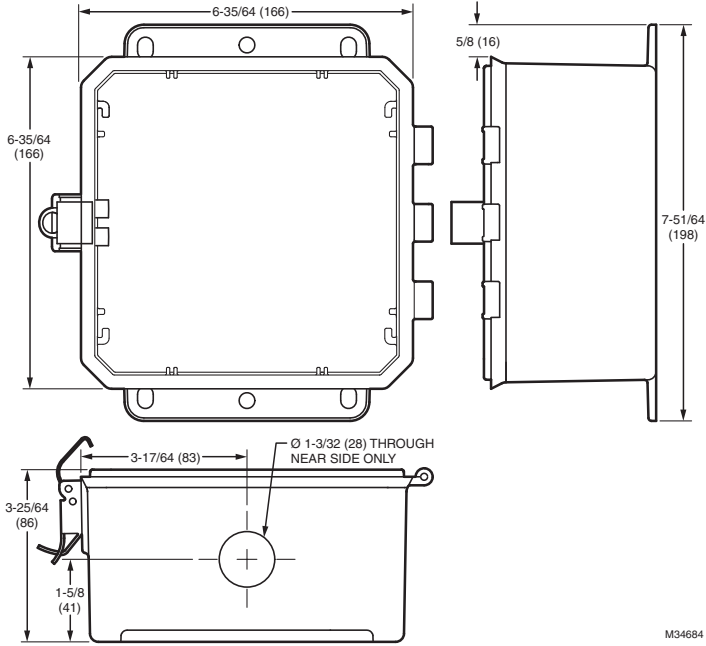

Fig. 5. Enclosure Dimensions

Use appropriately sized mounting hardware to fasten the meter enclosure to the selected mounting surface.

The four housing mounting holes are centered 6.75" H x 4" W.

NOTE: Units housed in UL Type 1 enclosures must only be installed in indoor environments, where they will not be affected by the elements.

6.2 Main Power Board Connections

1. Installing a temporary ground for ESD protection: With all circuits de-energized, connect a temporary protective earth ground connection for ESD protection. Prior to performing any unit wiring, be sure to discharge any static on your person.
2. Installing the Class 5000 protective earth ground: Connect an earth ground wire to the Class 5000 protective earth ground lug with a torque of 7 N-m. * for meters in metal enclosures.

WARNING

Failure to attach the protective earth ground wire securely to the meter creates a potential shock hazard. Do not operate the meter without a protective earth ground connection securely installed.

3. Wire Entry: One 3/4" conduit opening is located on the bottom of the unit enclosure. This opening is used for bringing in MAINS power and for current sensor wiring. Route the appropriate cabling to and through the respective enclosure opening.
4. After installing the conduit fitting and conduit, verify that each conduit slip nut is securely tightened to its respective conduit fitting. Any unused openings must be sealed with a UL rated plugging device suitable for the rating of the enclosure (check formatting).

NOTE: Metallic enclosure has one additional 1/2" conduit opening at top of unit.

5. Unit MAINS wiring: The first four positions of terminal block TB1, located at the bottom left corner of the main power board, are clearly labeled Phase A, B, C, N (neutral). Earth Ground MUST be connected to the PCB mounting screw in the lower right corner.
 - a. Connect the NEUTRAL wire to the appropriate terminal block position.

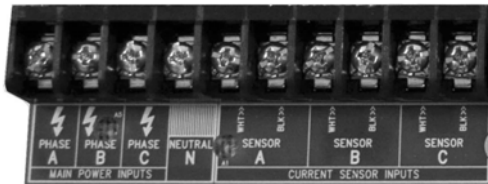

Fig. 6. Terminal Block TB1.

NOTE: For 3-wire delta-type applications, do NOT connect the NEUTRAL wire. Remove the terminal block screw for this position.

- b. Earth Ground. Connect the Earth Ground to the PCB mounting screw in the lower right corner.

- c. External Switch Mechanism/In-Line Fuse Installation.
To ensure a safe installation, the Class 5000 meter requires an external switch mechanism, such as a circuit breaker, be installed on the Class 5000 MAINS input wiring. The switch mechanism must be installed in close proximity to the meter and easily reachable for the operator. This device must also be marked as the disconnecting device for the Class 5000 meter. Install 1/10 Amp Slow Activation in-line fuses with the suitable voltage rating for each conductor phase at the MAINS input to the meter. The fuses must be labeled to indicate voltage and current rating as well as element characteristics. The fuse element must be slow activating type.

- d. Connect the three AC main power wires (Phases A, B and C) to their respective positions as labeled on terminal block TB1 and tighten to 7 in-lb. After all conductors are connected to each of their respective terminal block positions and tightened down, verify that each terminal block screw is securely fastened by gently tugging on each conductor.
NOTE: On Single phase connections: Connect two AC main power wires to phases A and B - Connect jumper from B to C - factory installed for “-SP” option. Verify that no conductor wires are frayed or shorting to adjacent terminal block positions.

- e. Turn ON the AC main power input. The meter display will light up and scroll through 7 displays. Each display is visible for 5 seconds. Display screens are as follows:
 - Screen 1 - Total kilowatt-hours (kWh) consumed*
 - Screen 2 - Peak demand (kW) with date & time stamp*
 - Screen 3 - Actual load (kW) with preset date & time*
 - Screen 4 - Average current (amps) per phase*
 - Screen 5 - Average voltage (volts) per phase*
 - Screen 6 - Average voltage (volts) phase to phase*
 - Screen 7 - Power factor (PF) per phase*

- f. Verify the voltage readings on Screen 5 using an AC voltmeter. Typical readings shown below are measured phase to neutral for 4 wire and phase to phase for 3 wire. Readings should be +/- 10% of nominal.

Meter Type	Nominal Voltage	Limits (+/- 10%)
120/208V, 3ø, 4 Wire 120/240V, 1ø, 3 Wire 120V, 1ø, 2 Wire	120 VAC (L-N)	108 to 132 VAC
277/480V, 3ø, 4 Wire 277V, 1ø, 2 Wire	277 VAC (L-N)	249 to 305 VAC
240V, 3ø, 3 Wire	240 VAC (L-L)	216 to 264 VAC
400V, 3ø, 4 Wire	230 VAC (L-N)	207 to 253 VAC
480V, 3ø, 3 Wire	480 VAC (L-L)	432 to 528 VAC
600V, 3ø, 4 Wire	347 VAC (L-N)	312 to 380 VAC

NOTE: Meters are powered by phases A and B. The displayed voltages will be the measured AC voltage between phases.

6.3 Phasing of Line Voltage

The 3-phase AC power input must be in proper phase sequence. Single phase “-SP” option - AC power input must be in proper phase sequence. If the sequence is incorrect or a phase is missing, there will be a message on the meter’s display: “PH Sequence Error” or “PH Missing:.” (Refer to the section on Line Voltage Diagnostics if this message is present.) When the line voltage is connected correctly, the meter’s display will be blank (no message.)

Wait for the meter display to scroll to the voltage display. Verify that the meter reads correct voltages on all three phases. Repeat Step 6.2.5.F.

Once the meter displays the correct line voltages and there are no error messages, you are ready to connect the current sensors to the meter. Before continuing with the installation, verify that the seven screens display as follows:

- Screen 1 (kWh): Should read 0.0 kWh; if not, should be reset.
- Screen 2 (kW Peak Demand): kW peak should read 0.0 kW. There will not be a date/time stamp yet. If there is a kW peak recorded, it should be reset later.
- Screen 3 (Load/Clock Calendar): Should read 0.0 kW load.
- Screen 4 (Amps per Phase): There should be 0.0 on all three phases. Or in the SP option - 0.0 in A and B phases.
- Screen 5 (Volts RMS Phase to Neutral): See the section 6.2.5.F.
- Screen 6 (Volts RMS Phase to Phase): See the section 6.2.5.F.
- Screen 7 (Power Factor Per Phase): There should be 0.0 PF on all three phases. Or in the SP option - 0.0 in A and B phases.

NOTE: The meter will be reset later via the software during “startup” procedures.

6.4 Current Sensor Installation & Wiring

Once the AC voltages have been confirmed to be within acceptable limits, you are ready to install the current sensors. TB2 is the input for Phase A, TB3 is the input for Phase B and TB4 is the Phase C input. For the SP option: use TB1 pos 5&6 are for the A Phase - TB1 pos 7&8 are for the B phase -factory installed jumper wire on positions 9&10. Factory installed Jumper should not be removed.

The Class 5000 meter can be used with two types of current sensors:

1. Split-core current sensor. This sensor opens so that it can be attached around the circuit being monitored without interrupting power. Unless otherwise specified, all Class 5000 meters are supplied with this sensor type.
2. Solid-core current sensor. This sensor does not open and requires the monitored conductor to be removed from the circuit to install the current sensor. This type is only supplied when specified at time of order.

6.4.1 Installing the Split-Core Current Sensor Assembly

1. Each phase being monitored will require one two-piece current sensor assembly. Open the two-piece current sensor assembly by releasing the nylon clamp using a fl at head screwdriver.



Fig. 7. Split Core Current Sensor.

2. Reassemble the current sensor assembly around the conductor(s) to be monitored. Ensure the current sensor halves marked "Load" are both facing the load side of the conductor. The colored arrow will be on the source side of the conductor being monitored and **MUST** be pointed in a clockwise direction around the conductor being monitored. Tighten the nylon clamp to complete the assembly.

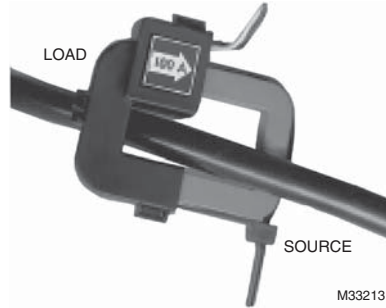

Fig. 8. Installation of a Split Core Sensor.

IMPORTANT:

When looking from the source side of the conductor(s) being monitored, you should see the arrow on the current sensor assembly. The arrow should be pointing in a clockwise direction around the conductor(s) being monitored. If the arrow is not positioned on the source side, inaccurate readings will result.

6.4.2 Current Sensor Wiring

Once the current sensors are installed onto their appropriate phase conductors, you can begin terminating the current sensors onto the Class 5000 main board. The current sensors can be extended up to 500 feet for remote monitoring applications. To extend the length of the wires, use #22 AWG twisted-pair wire with one white and one black wire.

The easiest way to connect the current sensors is to use the meter's built-in current sensor diagnostics. To do this, there must be at least 1% of the meter's current rating (amps) flowing in each of the conductors being monitored. The Class 5000 meter's diagnostic program will provide data to ensure that the current sensor installation is done properly.

The current sensor connection points are located at the bottom right of the main power board. These are terminals 5 through 10 of terminal block TB1. Each sensor connects to two terminals, one labeled "Black" and the other "White." Current sensors should be connected to the meter one at a time and verified using the current sensor diagnostic program.

Connect one of the current sensors to TB1 terminals 5 and 6 (Phase A). Wait 5 seconds and look at the meter display.

6.4.2 Current Sensor Wiring (continued)

If the meter displays an error message (see below), remove the wires from terminals 5 and 6 and install them on terminals 7 and 8 (Phase B). If an error message occurs with the sensor attached to terminals 7 and 8, try again on terminals 9 and 10 (Phase C).

The “CT Error: * “message will disappear when the current sensor is connected to the correct terminals (phase).

Error Messages: CT ERROR: A
CT ERROR: A B
CT ERROR: A C

NOTE: The 1-Phase option will only display errors for A and B.

Refer to the section on Current Sensor Diagnostics for assistance in troubleshooting these errors.

6.4.3 Main Power

After the meter circuit wiring has been examined for correctness, power may be applied to the circuit board. There are three LEDs located in the upper right corner of the Meter Board labeled BEAT, STATUS and LOAD. The BEAT and STATUS LEDs will blink once per second when the meter is operating normally, twice per second if there is a problem. If the monitored circuit is under load the LOAD LED will actively blink. A heavy load will cause the LED to blink faster than a light load. Very light loads will result in an extended blink time.

6.5 Main Power & Current Sensor Wiring Diagram

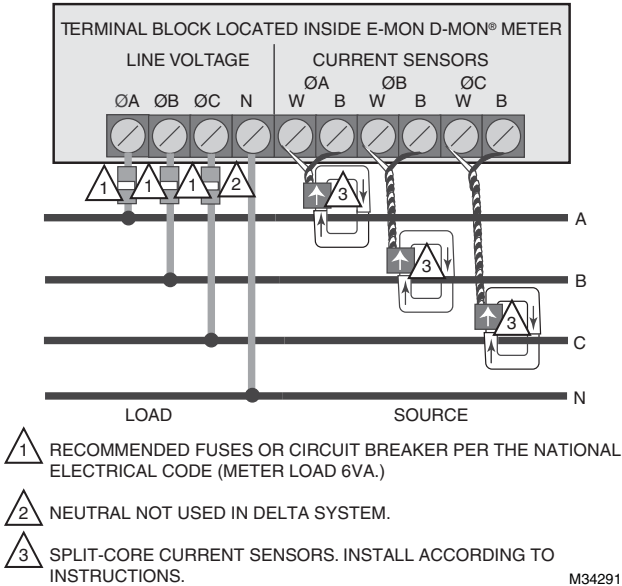

Fig. 9. 3-Phase - 3-Wire or 3-Phase - 4-Wire Installation Diagram.

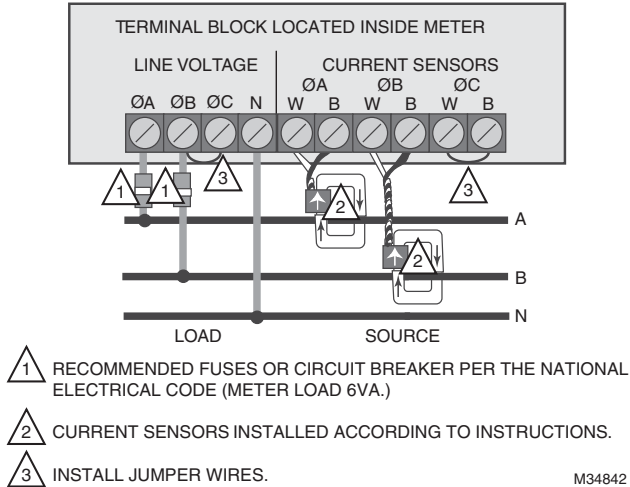

Fig. 10. Single-Phase, 3-Wire, 120/240, 120/208 or 277/480 Volt Installation Diagram

6.6 Line Voltage/Current Sensor Diagnostics

Following is a list of diagnostic messages that may appear on the meter display. DIAGNOSTIC MESSAGES SHOULD NOT BE ON CONTINUOUSLY WHEN THE METER IS INSTALLED PROPERLY AND IS IN WORKING ORDER.

6.6.1 Line Voltage Diagnostics

The diagnostics program detects line voltage faults by displaying one of two messages:

PH Missing: B C or Phase sequence error.

PH Missing: B C: Indicates that the line voltage is missing on Phase B and/or Phase C. This message will appear whenever the power on either Phase B or Phase C is off. Screen 5 (Voltage per Phase) will also indicate a loss of line voltage.

Phase sequence error. Indicates that the 1-phase or the 3-phase line voltage is not hooked up in the proper phase sequence. This message should never be seen continuously on the display during normal operation. The meter will not display correct electrical data in this condition. The phase sequence problem must be remedied in order for the meter to work properly.

6.6.2 Current Sensor Diagnostics

The load current must be at least 1% of the meter's rated load in order to use the diagnostic function. Current sensor diagnostics can detect:

1. Reversed current sensors
2. Incorrect phase correspondence
3. Unusually low power factor (0.642 or lower)

CT Error: (ABC) is used to detect the swapping of current sensor phases. This message could (in some rare cases) indicate a low (<65%) power factor condition. This message may appear intermittently due to changes in line conditions. It should not be on continuously.

NOTE: If you have connected the current sensor to all three terminals and the error message is still appearing, reverse the black and white wires and repeat the previous steps until the correct connection is found.

If the *CT Error:* message disappears, you have found the correct sensor connection; however, the current sensor was not installed properly around the conductor, or the sensor wires were extended and not spliced together correctly. Correct the sensor installation, reconnect the black wire to the black terminal and the white wire to the white terminal on the plug and reinstall the plug into the correct phase terminal for that current sensor. The error message should disappear and the current sensor is now installed properly.

If the *CT Error:* message does not disappear at any time while trying all 3 inputs both ways, check the AC voltage input from the current sensor between the black and white wires using an AC voltmeter. It will read approximately zero volts indicating that the load current is very small (or zero) or the current sensors are not secured properly (tight connection between core halves or lead splices not secure.)

Once the first current sensor is connected properly and the error message disappears, repeat the previous procedure for the remaining two current sensors. When all error messages have disappeared and all sensors are installed correctly, the meter is operational.

6.7 RS-485 Wiring

RS-485 communication allows a computer or modem to communicate with one or more Class 5000 meters. You can connect as many as 52 meters along a 4000-foot RS-485 cable run.

There are four communication protocols available through the Class 5000 RS-485 connection. They are EZ7, Modbus RTU, BACnet MS/TP, and Lonworks FT-10. The protocol is chosen when ordering the Class 5000 meter. A second protocol is available through the Ethernet port. The Ethernet protocol is also chosen when the meter is ordered. See ordering information for the available choices.

Daisy-Chain Method

This is the simplest method for connecting meters together.

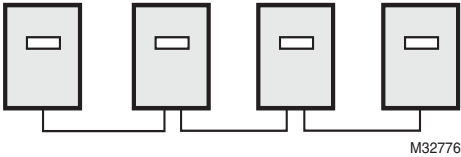

Fig. 11. Daisy-Chain Configuration.

1. Connect the +(high) terminal of PORT 1 of each meter together so that the + terminals on all meters are linked, + to + to +...
2. Connect the -(low) terminal of PORT 1 of each meter together so that the - terminals on all meters are linked, - to -...
3. Connect the GND terminals of PORT 1 of each meter so that the GND terminals on all meters are linked, GND to GND to GND.

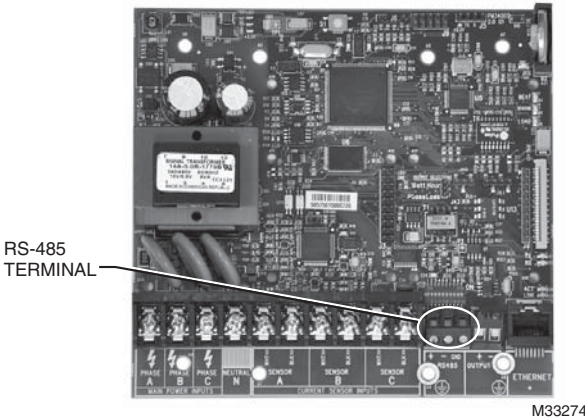

Fig. 12.

6.7 RS-485 Wiring (continued)

After performing these steps, all of the meters will be connected in a daisy chain configuration. This network of meters can then be connected to the RS-485 network and communication can be established.

Internal Modem

An optional internal modem inside one meter will communicate with the others via the RS-485 network. Simply connect one of the two telephone jacks on the modem to the telephone line to complete the installation.

Local Computer

A local computer installed in the building can communicate with the RS-485 network. The computer must be connected to an RS-232 key. The RS-232 key is then connected to an available RS-485 jack in the meter using an RJ-11 cable.

NOTE: Don't confuse the modem's telephone jacks with the RS-485 jacks!!!

NOTE: When using one meter with an external modem, only the telephone line is connected. RS-485 is not needed.

6.8 RS-232 Communications

6.8.1 Hardwired System using the RS-232 Communication Key

The RS-232 communications key allows you to connect Class 5000 meters to a personal computer that has the E-Mon Energy™ software installed. The computer communicates with the meters through the RS-232 key.

The RS-232 key must be located within 15 feet of the host computer.

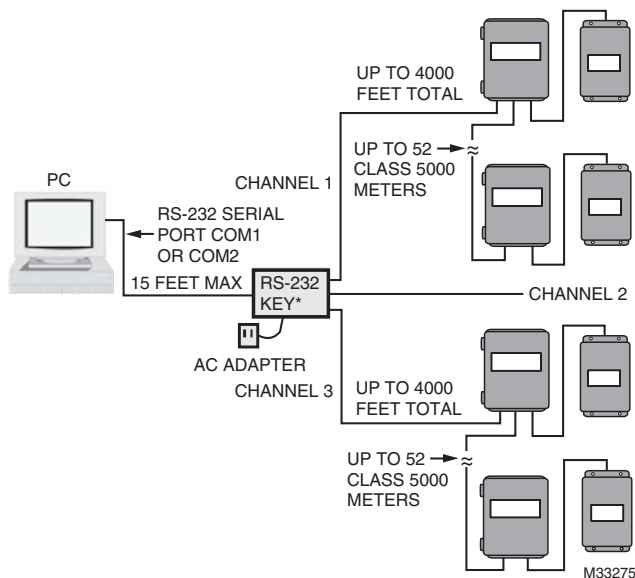

Fig. 13. RS-232 Configuration.

6.8.2 Connecting the RS-232 Key to the Computer

The RS-232 key is supplied with:

- (1) 8-conductor cable fitted with RJ-45 plugs
- (1) DB-9 serial COM port adapter
- (1) AC adapter that converts 120VAC to 9VDC for powering the RS-232 key

Connection Steps:

- Connect the 8-conductor cable to the left-side jack (labeled "RS232") on the rear panel of the RS-232 key.
- Connect the appropriate COM port adapter (DB-9) to the serial port on the back of the computer. Plug the 8-conductor cable from the RS-232 key into the COM port adapter.
- Connect the provided AC adapter into the rear panel input on the RS-232 key. Plug the adapter into a 120VAC outlet. On the front panel of the RS-232 key, two LEDs (POWER ON and AC ON) will light up.

NOTE: *When the E-Mon Energy™ software is accessed on the computer, a third LED (RS232 READY) will turn on. This indicator will light up as soon as the E-Mon Energy software is booted up and the correct COM port is set up via the settings provided in the software's Locations menu.*

6.8.3 Connecting Class 5000 Meters to the RS-232 Key using RS-485

On the rear panel of the RS-232 key, there are three jacks labeled as channels A, B and C. These are RS-485 serial communications ports used to connect the meters. Each of these channels can be connected to as many as 52 individual meters over a total cable distance of 4,000 feet. The channels are independent and must not be connected to each other.

Modular Plug Method

This simple method requires using 4 stranded conductors inside a cable that is fitted with an RJ-11 type plug for 4-conductor modular systems at each end of the cable.

*Do not use any pre-made telephone cables.

1. Plug the 4-wire RJ-11 cable/plug assembly into Channel A on the RS-232 key. Connect the other end of this cable to the meter via the RS-485 port, (PORT 2) at the bottom right of the Class 5000 meter main power board.

NOTE: The total combined cable length must not be more than 4000 feet.

2. Each meter has one yellow (TX) and one green (RX) LED located on the right side of meter board just below the ribbon cable. If the system is properly wired, these two LEDs will be OFF. These LEDs will flash when the computer and meter are communicating.

6.9 Modem Wiring

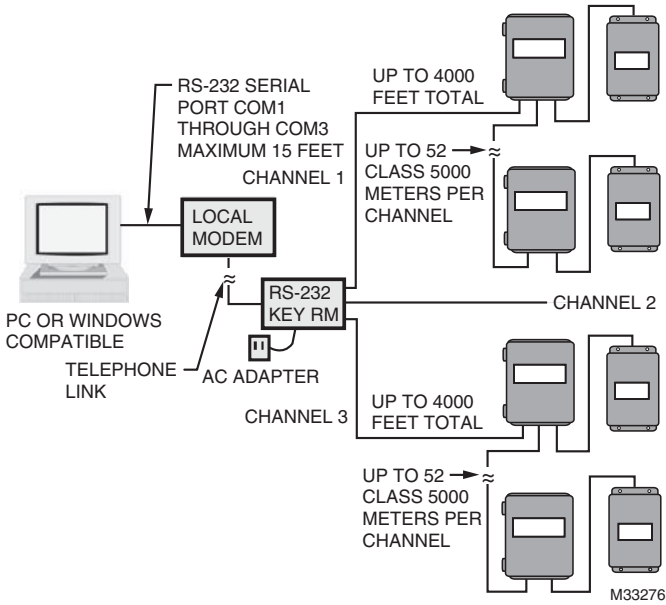

Fig. 14. Modem Configuration.

6.9.1 Built-In Modem (RS-232 KEY RM)

The RS-232 key with built-in modem connects the entire RS-485 network of Class 5000 meters to a telephone line.

** Refer to Section 6.7 for RS-485 network connections.

On the back panel of the RS-232 key/modem, the left jack (RS232) is not used in most cases since there is no local host computer.

The two jacks at the top center of the rear panel on the RS-232 key/modem are for connecting the phone line. Connect either one of these two jacks to the telephone line.

IMPORTANT:

The telephone line should be dedicated exclusively to the automatic meter reading system. Never connect to a telephone line used by other modems or fax machines. If there are telephones connected to this phone line, the proprietor must be aware that all phones must be on "hook" in order for the modem to work. A dedicated phone line is suggested for system reliability.

6.9.2 External Modem

1. All meters should be connected to the RS-232 key as described in 6.8.2. 2.
2. DISCONNECT POWER TO THE RS-232 KEY. Remove the cover by removing the 2 screws from the bottom of the enclosure.
3. On the circuit board, locate the blue jumpers J7 (MODEM) and J8 (ex-MODEM). If these jumpers are set in the DIRECT position, you must move the jumpers so they are set in the MODEM position. Re place the cover and secure the enclosure.
4. Connect the RS-232 key to the external modem using the supplied 8-conductor fl at modular cable.
5. Connect the 9VDC adapter to the power input on the back of the RS-232 key and plug it into a 120VAC outlet.

IMPORTANT:

The modem should use a phone line that is dedicated exclusively to the AMR system. Do not use a phone line that is shared by another modem or fax machine.

6.9.3 Baud Rate Selection

The communication baud rate is selected by means of a jumper on the circuit board. There are four (4) selections: 9600 (factory default), 19200, 38400, and 76800.

1. Select 9600 when using the Class 5000 meter with a modem.
2. The baud rate on the meter must always match the baud rate selected in the E-Mon Energy software; otherwise, communications will not work.
3. After a baud rate change, press CPU Reset to register the change.
4. All meters in the daisy-chain circuit must be set at the same baud rate.
5. The DIP switch is located above the RS-485 terminals.
6. Using other than 9600 BAUD will reduce the maximum cable length allowed for communication.

NOTE: USE ONLY POSITIONS 3 AND 4 - DO NOT CHANGE ANY OTHER POINTS.

The selections are noted below.

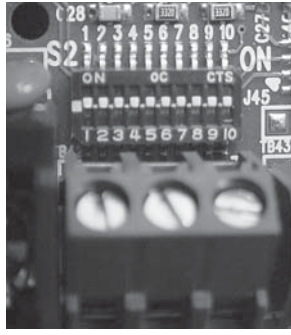

Fig. 15. Baud Rate Selection

3	4	Baud rate
ON	ON	9600 (EZ-7, modbus RTU, BACnet MS/TP)
OFF	ON	19200 (EZ-7, modbus RTU, BACnet MS/TP)
ON	OFF	38400 (Modbus RTU, BACnet MS/TP)
OFF	OFF	78600 (Bacnet MS-TP)

6.9.4 Dip Switch Settings

Option	COMMUNICATION PROTOCOLS		Firmware PN#	PROTOCOL		BAUD RATE	
	RS-485 Port	Ethernet Port		SW1	SW2	SW3	SW4
01	EZ7	EZ7	Modbus	ON	ON	ON	ON
02	Modbus RTU	EZ7	Modbus	OFF	ON	ON	ON
03	BACnet MS/TP	EZ7	BACnet MS/TP	OFF	ON	ON	OFF
04	EZ7	Modbus TCP/IP	Modbus	ON	OFF	ON	ON
05	EZ7	BACnet IP	BACnet IP	ON	OFF	ON	ON
06	Modbus RTU	Modbus TCP/IP	Modbus	OFF	OFF	ON	ON
07	LonWorks TP/FT-10	EZ7	LonWorks	X	ON	ON	ON
08	LonWorks TP/FT-10	Modbus TCP/IP	LonWorks	X	OFF	ON	ON
09	EZ7 w/ Modem	EZ7	Modbus	ON	ON	ON	ON
10	EZ7 w/ Modem	Modbus TCP/IP	Modbus	ON	OFF	ON	ON
11	EZ7 w/ Modem	BACnet IP	BACnet IP	ON	OFF	ON	ON

NOTE: *Protocol selections are done via DIP Switch (S2); pos 1 for RS-485 and pos 2 for Ethernet. When the DIP switch is in the ON position, EZ7 protocol will be active. Changing protocol setting requires restarting the CPU. DIP Switch indicating by X means don't care.

NOTE: Pass Through Feature - S2 position 8 - to off - ethernet to RS485 pass through - only valid with EZ7 protocol. -S2 position 8 - on - true dual protocol settings.

6.10 Modbus RTU Wiring

The Class 5000 Modbus meter communicates with building automation equipment over a 2-wire (3-conductor) RS-485 network using Modbus RTU protocol. The meters are networked in a daisy-chain configuration (Section 6.7) with BELDEN 1120A cable or equivalent. The cable rating of 600V allows the RS-485 network to be connected to 480-volt meters. Up to 52 meters can be installed on a network string. The maximum combined length of all daisy-chained cables must not exceed 4000 feet.

The meter-to-network connection is through the 3-screw terminal which is located on the Main Power Board of the meter.

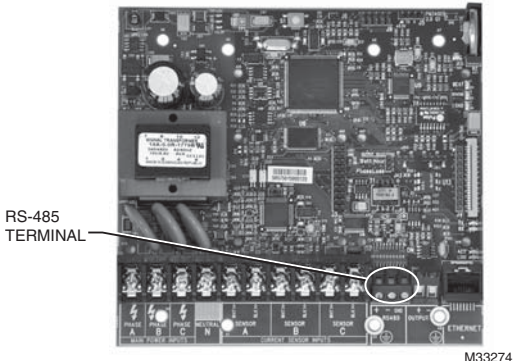

Fig. 16. Modbus R Wiring.

The meter is shipped with a Modbus ID number of 01. This must be changed if the network has more than one meter installed. The change must be done before the meter is introduced into the network. The meter can be numbered from 1 to 247. There can be no duplicate numbers on a network, so caution must be taken when assigning a meter ID number prior to its installation on the RS-485 network.

SEE SECTION 10 FOR INSTRUCTIONS ON CHANGING ID AND IP ADDRESSES.

6.11 BACnet MS/TP Wiring

BACnet MS/TP wiring is the same as Modbus and EZ7 wiring. See Sections 10 and 11 for instructions on changing I.D. and IP addresses.

6.12 Connecting Class 5000 Meters to the USB Key using RS485

The USB Key plugs into the PC's USB port and provides a termination point for the RS485 wiring from the meters. Up to 52 meters can be "Daisy chained" with up to 4000 feet total RS485 wiring. The USB Key is labeled for "plus (+)", "minus (-)", and ground and the wiring must match the same positions on the meters. If more than 52 meters are to be monitored, additional USB Keys can be utilized to connect them to the PC.

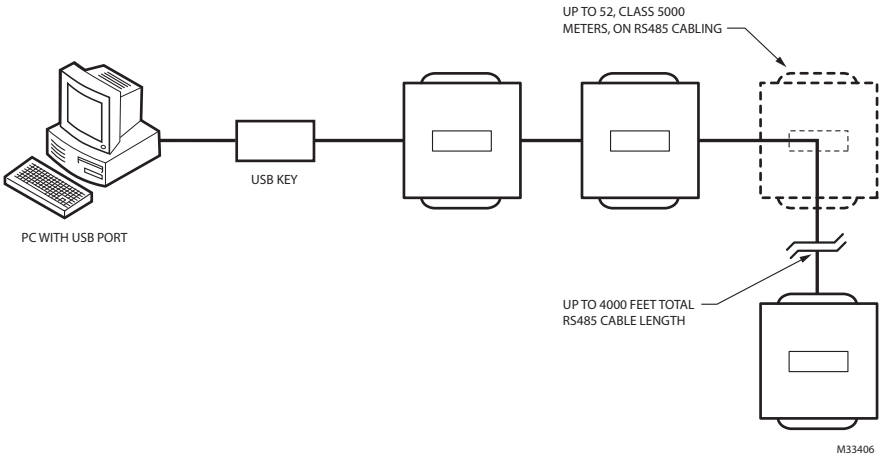

Fig. 17. Connecting Class 5000 Meters to the USB Key using RS485.

6.13 Ethernet Communications

Ethernet/IP communications connections are provided through an RJ-45 connector(J8) in the lower right corner of the main power board. This port can be connected directly to a network port of a PC using a Cat. 5e crossover cable.

Two LEDs are provided directly above the connector. The LINK LED is yellow and when lit, indicates ethernet connectivity. The ACT led is green and when lit, indicates communication activity. The communication protocol for the Ethernet port is selected when ordering the meter. The available choices are EZ7, Modbus TCP/IP and BACnet IP. See the ordering information for the available choices in combination with the RS-485 output.

Class 5000 Ethernet/IP Addressable meters can be tied into a local Ethernet network individually, or a single Ethernet-connected meter can communicate with multiple RS-485 daisy-chained conventional class 5000 meters using a single IP address. Each device that is connected directly to the ethernet network requires a unique IP address.

SEE SECTION 10 FOR INSTRUCTIONS ON CHANGING ID AND IP ADDRESSES.

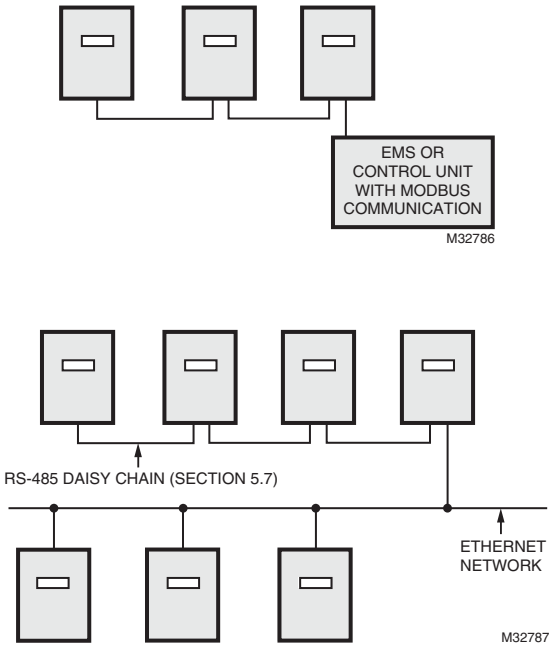

Fig. 18. Ethernet/IP Communications.

7.0 MULTIPLE-LOAD MONITORING

The E-Mon D-Mon Class 5000 meter provides extreme flexibility by allowing additional sets of current sensors to be used in parallel so multiple load locations can be monitored by one meter. This feature allows a totalized display readout from two or more load circuits.

You may use parallel sensors to monitor specific breakers from one panel, specific breakers from more than one panel, two or more complete panels, etc. When paralleling current sensors, the following rules must be followed for accurate readings:

1. Current sensors must be installed in complete sets of three, with a maximum of three sensors installed in parallel per phase.
NOTE:-In 1-phase option - sensors must be installed in set of 2 with maximum of three sensors per phase.
2. All sensors used in parallel must be of the same amperage rating (all 100-amp, all 400-amp, etc.) The rating is determined by the current rating of the meter.
3. All locations being monitored must have the same power source. A 480-volt meter cannot monitor a 208-volt load, nor can a meter monitor two-480 volt loads if they are from different originating power sources or from different transformers.
4. Multiply the meter display readings by the number of sets of current sensors installed. Example: Meter readings of 5 kWh with 2 sets of current sensors - 10 kWh is the actual usage. ($5 \times 2=10$.)

NOTE: One set of current sensors equates to three sensors, one per phase. The multiplier only applies when extra sets of current sensors are installed on one meter. If you are using only one set of three current sensors, the multiplier is not required.

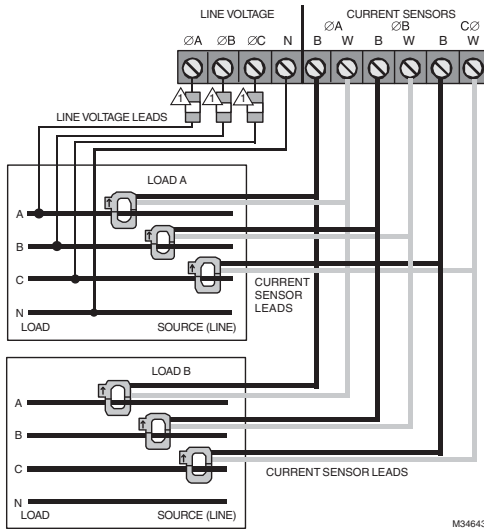
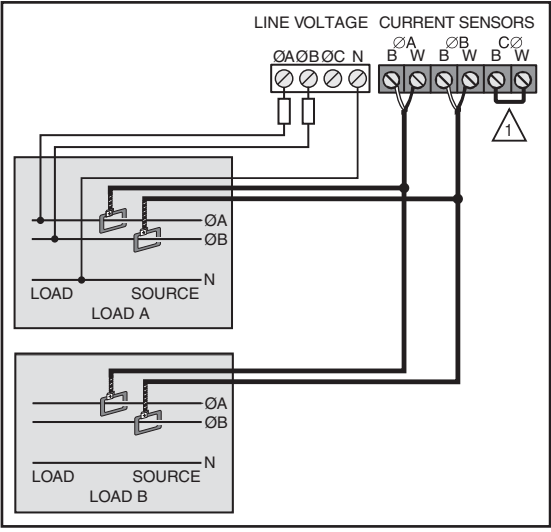

Fig. 19. Multiple-load Wiring Diagram.



1 INSTALL JUMPER WIRE.

M34644

Fig. 20. Single Phase Multiple Load Diagram.

8.0 PREVENTATIVE/SCHEDULED MAINTENANCE

The unit is shipped in a calibrated and fully functional tested condition. Since the unit is factory-calibrated using proprietary firmware algorithms, no internal unit adjustments are necessary.

This unit contains no internal adjustments, so no preventative or scheduled maintenance is required.

No cleaning or decontamination procedures are required for this instrument.

9.0 LITHIUM BATTERY REPLACEMENT INSTRUCTIONS

The Class 5000 kWh/Demand meter has a Lithium Battery Cell, which is used to retain the contents of SRAM and the RTC during power outages. The battery has a life expectancy of greater than 5 years.

Nominal Working Voltage	3 Vdc Output
Nominal Current Capacity	225 mAHr
Cell Chemical	Manganese Dioxide Lithium
Operating Temperature Range	-30 to +60 Degrees Celsius
Manufacturer	Panasonic
Manufacturer's Part Number	CR2032

Fig. 21. Battery Specifications at 25 Degrees Celsius.



WARNING

Only replace battery with Panasonic part number CR2032 only. Use of another battery may present a risk or explosion. See owners manual for safety instructions. Internal circuit card components are extremely sensitive to electrostatic discharge. Be careful not to touch internal circuitry prior to discharging any static buildup on your person. To discharge yourself, touch a grounded metal object such as conduit or a metal enclosure exterior.

The battery cell is mounted in a coin cell on the upper right side of the main power board. Replace the battery if the low battery warning is on display.

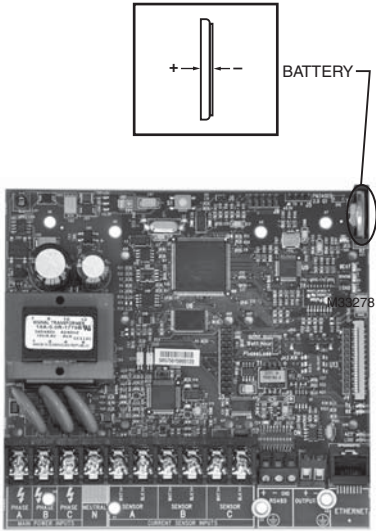

Fig. 22. Lithium Battery Cell.

Use the following procedure to replace the battery cell:

- STEP 1: Disconnect power from the meter at the unit external circuit breaker.
- STEP 2: Remove the battery from its holder and place on a non-conductive surface.
- STEP 3: Install new battery into the battery holder.

NOTE: Care should be taken to insure that the replacement battery is installed the same polarity as the battery that was removed. No damage to unit or battery will occur if battery is inadvertently installed in the wrong direction.

STEP 4: Dispose of the used battery in accordance with the manufacturers' (Panasonic) instructions.

10.2 Normal Mode Display Screens

The Class 5000 meter features seven Normal Mode Display Screens for monitoring the meter. Each screen is displayed for 5 second intervals, before scrolling onto the next screen.

You can "lock" the scrolling display on any one of the seven screens. This will be explained in detail on following pages.

Explanations of the Normal Mode Display Screens are as follows:

Screen 1: Total Kilowatt-Hours (kWh)
Delivered.

TOTAL :	123 KWH
	>

Screen 2: Peak Demand (kW)
with Date & Time Stamp

KW PEAK:	25.5 KW
ON DATE:	05/15
AT TIME:	11:45

Screen 3: Actual Load (kW)
with Present Time

LOAD:	24.0 KW
DATE:	06/14/11
TIME:	08:46:58

Screen 4: Average Current (amps)
Per Phase.
Note: 1-Phase option will only state:
PH-A and PH-B.

PH-A:	12.3 AMPS
PH-B:	10.2 AMPS
PH-C:	14.7 AMPS

Screen 5: Average Voltage (volts)
Per Phase.
Note: 1-Phase option will only state:
PH-A and PH-B.

PH-A:	119.8 VOLTS
PH-B:	120.2 VOLTS
PH-C:	119.5 VOLTS

Screen 6: Average Voltage (volts)
Phase to Phase.
Note: 1-Phase option will only state:
P-AB and P-BA.

P-AB:	0.0 VOLTS
P-BC:	0.0 VOLTS
P-CA:	0.0 VOLTS

Screen 7: Power Factor (pf)
Per Phase.
Note: 1-Phase option will only state:
PH-A and PH-B.

PH-A:	0.0 % PF
PH-B:	0.0 % PF
PH-C:	0.0 % PF

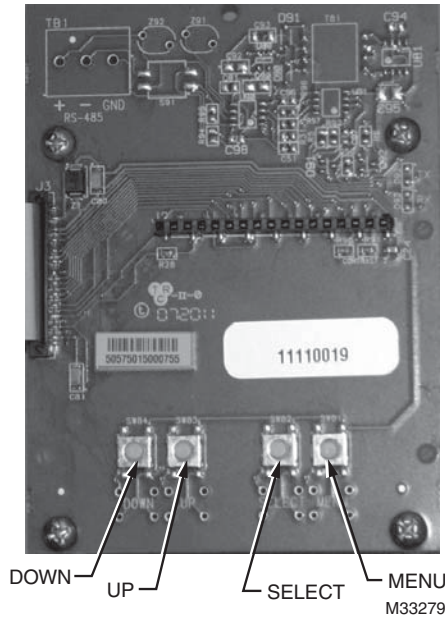

Fig. 23. Push Buttons.

10.3 How to Program the Display Screens

The display information can be programmed using four push buttons switches. The push buttons (DOWN, UP, SELECT, MENU) are located at the top of the display board on the inside front door of the meter. The buttons are used to program the following:

- Date & Time (This field sets the month, day, year, and time).
- Device ID (This field changes the default setting, which is 1A for EZ7 and 2 for ModBus).
- IP Settings (This field allows you to select the DHCP or static IP address, mask and gateway information).
- Reset KW/KWH Read (This field resets the Peak kW Demand to zero).

10.3.1 Date & Time Display Screen

To change the date and time, complete the following steps:

1. Press the MENU button.
2. The following screen will appear:

```
—> DATE & TIME
    DEVICE ID
    IP SETTINGS
    RESET KW/KWH READ
```

3. Press the SELECT button. The Date and Time Screen will appear, and the 2 digit month will be blinking.

```
DATE: 02-16-2012
TIME: 01:57:36
```

4. Use UP or DOWN button to make changes, press the SELECT button to advance to the next setting. Repeat this step until all the date and time settings have been updated.
5. If changes were made, you'll be asked to save, press UP or DOWN to select Y or N.

```
Save changes: Y / N
```

6. Press SELECT to save new settings. This will also return you to main menu. In main menu, select EXIT to get out of programming mode and return to normal display mode.

10.3.2 Device I.D. Display Screen

To change Device I.D., complete the following steps:

1. Press the MENU button.
2. The following screen will appear:

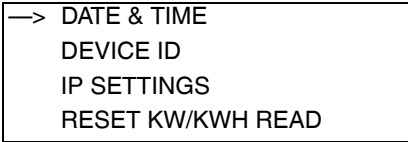

3. Use UP or DOWN button until the arrow is on the Device ID line.

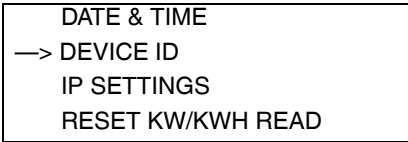

4. Press the SELECT button. The Device ID Screen will appear.

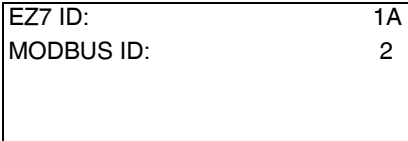

5. Use UP or DOWN button to make changes, press the SELECT button to advance to the next setting. Repeat this step until all the settings have been updated.
6. If changes were made, you'll be asked to save, press UP or DOWN to select Y or N.

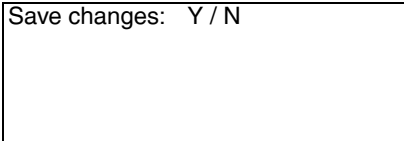

7. Press SELECT to save new settings. This will also return you to main menu. In main menu, select EXIT to get out of programming mode and return to normal display mode.

10.3.3 IP Setting Display Screen

To Change the IP settings, complete the following steps:

1. Press the MENU button.
2. The following screen will appear:

→ DATE & TIME
DEVICE ID
IP SETTINGS
RESET KW/KWH READ

3. Use UP or DOWN button until the arrow is on the IP Setting line.

DATE & TIME
DEVICE ID
→ IP SETTINGS
RESET KW/KWH READ

4. Press the SELECT button. The IP Setting Screen will appear.

ENABLE DHCP?	N	
IP:	192.168.	0.168
MSK:	255.255.255	0
GWY:	192.168. 0.	1

5. Use UP or DOWN button to make changes, press the SELECT button to advance to the next setting. Repeat this step until all the settings have been updated.
6. If changes were made, you'll be asked to save, press UP or DOWN to select Y or N.

Save changes:	Y / N
---------------	-------

7. Press SELECT to save new settings. This will also return you to main menu. In main menu, select EXIT to get out of programming mode and return to normal display mode.

10.3.4 Peak Demand Reset

To reset the recorded peak kW demand, complete the following steps:

1. Press the MENU button until “Reset kW/kWh Read” is indicated by the arrow on the display.

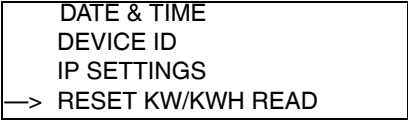

2. Press the SELECT button. The following screen will appear on the display.

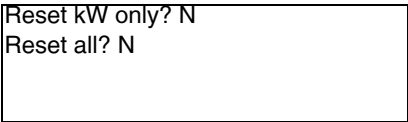

3. Press the UP button to change the N to a Y after “Reset kW only?”.
4. The peak demand will be reset to zero and the meter will return to its normal scrolling display mode.

10.3.4 Display Hold Feature

You can “lock” the scrolling display so that it will stay locked on any one of the six screens.

To stop the display from scrolling, complete the following steps:

1. Press the UP and DOWN buttons to choose which of the six screens you would like to display.
2. Press the Select button. At the top of the display, you will see the message HOLD1. This will lock the display for 1 HOUR.

NOTE: The display hold feature has different selectable time periods.

3. Pressing Select again will show the message HOLD6. This will lock the display for 6 HOURS.
4. Continuing to press the Select button will provide additional timing choices:

HOLD12: Locks the display for 12 HOURS
HOLD24: Locks the display for 24 HOURS
HOLD: Locks the display indefinitely

To exit the HOLD mode:

Press the Select button as many times as needed until the HOLD message disappears from the display.

** Be sure to exit from the HOLD mode when you are done using this feature.

11.0 FREQUENTLY ASKED QUESTIONS

- Q. When providing line voltage to the meter, can I tap off of the same breaker I am monitoring?
- A. Yes, the voltage can be pulled from the same breaker being monitored.
- Q. Can the meter's line voltage wires be run in the same conduit as the sensor leads?
- A. Yes. There will be no effect if the sensor leads and line voltage wires are run in the same conduit.
- Q. Can the meter's communication wires and line voltage be run in the same conduit?
- A. It is not recommended to run these wires together due to noise concerns and their effects on the communications signal integrity. Communications wires can be routed separately using a 1/2" conduit port.
- Q. How do I find the cost for kWh and kW to bill my tenants?
- A. Your local utility bill should list the cost per kWh and kW. If not, simply call your utility and ask them to provide you with the cost per kWh and kW.
- Q. What size wire do I use for the line voltage leads?
- A. These wires are normally sized at #14 AWG, but be sure to confirm this requirement with your local and national electrical code requirements.
- Q. What size wire should I use to extend the current sensor leads?
- A. These wires are normally 14-22 AWG, twisted-pair arrangement. Consult your electrical code for proper wiring requirements.

- Q. The load I need to monitor has parallel feeds. How do I install the current sensors for this application?
- A. There are two ways you can monitor parallel feeds. The easiest and preferred method is to clamp the sensors around all feed wires for each phase. The second way to monitor parallel feeds is to clamp the sensor around one of the feed wires for each phase. When you read the Class 5000 meter, the final reading must be multiplied by the number of feed wires for each phase.
- Q. I have two subpanels I would like to monitor with one Class 5000 meter. These subpanels are fed by different transformers in the building. Can I parallel sensors and monitor both panels with one meter?
- A. No. These panels cannot be monitored with one meter because they are different power sources. When you parallel current sensors, all loads being monitored must be from the same voltage source.
- Q. I have 5 breakers in one subpanel I would like to monitor with one class 5000 meter. Can this be done without having to parallel current sensors?
- A. Yes. Simply run all the breaker wires through one set of current sensors. Make sure all A-phase circuits are run through the A-phase sensor, and the same for B & C phases. The meter should be sized by the highest amount of current being monitored by one sensor.
- Q. I've gone through the troubleshooting guides and I still can't get my class 5000 meter to work. What should I do?
- A. Before removing the unit, contact E-Mon's technical services department at (800) 334-3666. E-Mon's technical department will assist you in detailed troubleshooting of the meter installation and assist you in getting the unit running without having to remove and/or return it.

12.0 PROTOCOL DESCRIPTIONS

ModBus Customer Point Map: CL5000					
Address	Registers	Format	Description	Units	CL 5000
40001 ¹	2	Integer	Energy delivered	Wh Pulse	R/W
40003 ¹	2	Integer	Energy received	Wh Pulse	R/W
40005 ¹	2	Integer	Reactive energy delivered	VARh Pulse	R/W
40007 ¹	2	Integer	Reactive energy received	VARh Pulse	R/W
41001 ¹	2	Float	Energy delivered	kWh	R/W
41003 ¹	2	Float	Energy received	kWh	R/W
41005 ¹	2	Float	Reactive energy delivered	kVARh	R/W
41007 ¹	2	Float	Reactive energy received	kVARh	R/W
41009	2	Float	Real power	kW	R
41011	2	Float	Reactive power	kVAR	R
41013	2	Float	Apparent power	kVA	R
41015	2	Float	Power factor	% PF	R
41017	2	Float	Peak demand	kW	R
41019	2	Float	Current average	Amps	R
41021	2	Float	Voltage line-neutral	Volts-N	R
41023	2	Float	Voltage line-line	Volts-L	R
41025	2	Float	Frequency	Hz	R
41027	2	Float	Phase angle	Degree	R
41029	2	Float	Real power, phase A	kW	R
41031	2	Float	Real power, phase B	kW	R
41033	2	Float	Real power, phase C	kW	R

ModBus Customer Point Map: CL5000					
Address	Registers	Format	Description	Units	CL 5000
41035	2	Float	Reactive power, phase A	kVAR	R
41037	2	Float	Reactive power, phase B	kVAR	R
41039	2	Float	Reactive power, phase C	kVAR	R
41041	2	Float	Apparent power, phase A	kVA	R
41043	2	Float	Apparent power, phase B	kVA	R
41045	2	Float	Apparent power, phase C	kVA	R
41047	2	Float	Power factor, phase A	% PF	R
41049	2	Float	Power factor, phase B	% PF	R
41051	2	Float	Power factor, phase C	% PF	R
41053	2	Float	Current, phase A	Amps	R
41055	2	Float	Current, phase B	Amps	R
41057	2	Float	Current, phase C	Amps	R
41059	2	Float	Voltage, line to neutral, phase A-N	Volts-N	R
41061	2	Float	Voltage, line to neutral, phase B-N	Volts-N	R
41063	2	Float	Voltage, line to neutral, phase C-N	Volts-N	R
41065	2	Float	Voltage, line to line, phase A-B	Volts-L	R
41067	2	Float	Voltage, line to line, phase B-C	Volts-L	R
41069	2	Float	Voltage, line to line, phase C-A	Volts-L	R
41071	2	Float	Phase angle, phase A	Degree	R
41073	2	Float	Phase angle, phase B	Degree	R
41075	2	Float	Phase angle, phase C	Degree	R

CLASS 5000 METER

ModBus Customer Point Map: CL5000					
Address	Registers	Format	Description	Units	CL 5000
41083 ²	2	Float	External Input 1	Pulse	R/W
41085 ²	2	Float	External Input 2	Pulse	R/W
44001 ³	6	Custom	Interval Day Block		R/W
44007 ⁴	1 per interval	Integer	Interval Data	Pulse	R
45501 ⁵	2 per day	Custom	Interval Data Headers		R
46025 ⁶	8	Custom	RTC Date/Time		R/W
46049 ⁷	8	Custom	EZ7 ID, ModBus ID, Serial Number		R/W
46057	8	Custom	Recorder Info., Demand Interval		R/W
46513	8	Custom	Flags L1: Power Failure, Battery		R
46521	8	Custom	Flags L2: Power Failure Date		R
<p>1. To clear single meter kWh/kVARh, set multiple points at 40001 or 41001 for 8 points with data set to 0000 0000 0000 0000 0000 0000 0000 0000.</p>					
<p>2. External inputs are standard on Class 5000 meters and optional on Class 3400 meters (Part of Expanded Feature Package).</p>					
<p>To clear external inputs, set multiple points at 41083 or 41085 for 2 points with data set to 0000 0000. Jumper J6 must be closed. Remove J6 when changes have been completed.</p>					
<p>3. To set the interval data day block, set multiple points at 44001 for 6 points with data set to 0C0I 0000 MMDD YYYY 0000 0000.</p>					
<p>0C = Channel, 0I = Interval (0F = 15 minute intervals, 05 = 5 minute intervals)</p>					
<p>4. Each register represents a 15 or 5 minute kWh pulse value based on the interval day block. 96 registers max with 15 minute intervals. 288 registers max with 5 minute intervals. The first interval data register 44007 represents the pulse count for the first 15 or 5 minute interval beginning at midnight.</p>					
<p>5. The interval data headers represent days with available interval data. Each day represents 2 registers. Format: MMDD YYYY.</p>					
<p>6. To set the date and time, set multiple points at 46025 for 4 points with data set to HHMM SSDW MMDD YYYY (DW=day of week)</p>					
<p>7. To change the ModBus ID, set single point at 46050 with data set to new ModBus ID (e.g. 1 to 247). Jumper J6 must be closed. Remove J6 when changes have been completed.</p>					

BACnet Object Descriptors: CL5000					
Instance ID	BACnet Object	Description	Units	BACnet Property	CL 5000
1 ¹	Analog Input	Energy delivered	kWh	Present Value	R
2 ¹	Analog Input	Energy received	kWh	Present Value	R
3 ¹	Analog Input	Reactive energy delivered	kVARh	Present Value	R
4 ¹	Analog Input	Reactive energy received	kVARh	Present Value	R
5	Analog Input	Real power	kW	Present Value	R
6	Analog Input	Reactive power	kVAR	Present Value	R
7	Analog Input	Apparent power	kVA	Present Value	R
8	Analog Input	Power factor	% PF	Present Value	R
9	Analog Input	Peak demand	kW	Present Value	R
10	Analog Input	Current average	Amps	Present Value	R
11	Analog Input	Voltage line-neutral	Volts-N	Present Value	R
12	Analog Input	Voltage line-line	Volts-L	Present Value	R
13	Analog Input	Frequency	Hz	Present Value	R
14	Analog Input	Phase angle	Degree	Present Value	R
15	Analog Input	Real power phase A	kW	Present Value	R
16	Analog Input	Real power phase B	kW	Present Value	R
17	Analog Input	Real power phase C	kW	Present Value	R
18	Analog Input	Reactive power phase A	kVAR	Present Value	R
19	Analog Input	Reactive power phase B	kVAR	Present Value	R

CLASS 5000 METER

BACnet Object Descriptors: CL5000					
Instance ID	BACnet Object	Description	Units	BACnet Property	CL 5000
20	Analog Input	Reactive power phase C	kVAR	Present Value	R
21	Analog Input	Apparent power phase A	kVA	Present Value	R
22	Analog Input	Apparent power phase B	kVA	Present Value	R
23	Analog Input	Apparent power phase C	kVA	Present Value	R
24	Analog Input	Power factor phase A	% PF	Present Value	R
25	Analog Input	Power factor phase B	% PF	Present Value	R
26	Analog Input	Power factor phase C	% PF	Present Value	R
27	Analog Input	Current phase A	Amps	Present Value	R
28	Analog Input	Current phase B	Amps	Present Value	R
29	Analog Input	Current phase C	Amps	Present Value	R
30	Analog Input	Voltage line-neutral phase A-N	Volts-N	Present Value	R
31	Analog Input	Voltage line-neutral phase B-N	Volts-N	Present Value	R
32	Analog Input	Voltage line-neutral phase C-N	Volts-N	Present Value	R
33	Analog Input	Voltage line-line phase A-B	Volts-L	Present Value	R
34	Analog Input	Voltage line-line phase B-C	Volts-L	Present Value	R
35	Analog Input	Voltage line-line phase C-A	Volts-L	Present Value	R
36	Analog Input	Phase angle phase A	Degree	Present Value	R
37	Analog Input	Phase angle phase B	Degree	Present Value	R
38	Analog Input	Phase angle phase C	Degree	Present Value	R

BACnet Object Descriptors: CL5000					
Instance ID	BACnet Object	Description	Units	BACnet Property	CL 5000
39	Analog Input	Reserve A	No units	Present Value	R
40	Analog Input	Reserve B	No units	Present Value	R
41	Analog Input	Reserve C	No units	Present Value	R
42 ²	Analog Input	External Input 1	Pulse	Present Value	R
43 ²	Analog Input	External Input 2	Pulse	Present Value	R
<p>1. To clear single meter kWh/kVARh, select reset kW/kWh on the display menu of the meter. This function will also reset external inputs. Jumper J6 must be closed. Remove J6 when changes have been completed.</p>					
<p>2. External inputs are standard on Class 5000 meters and optional on Class 3400 meters (Part of Expanded Feature Package). To clear external inputs, select reset kW/kWh on the display menu of the meter. This function will also reset kW/kVARh. Jumper J6 must be closed. Remove J6 when changes have been completed.</p>					

CLASS 5000 METER

Instance ID	BACnet Object	BACnet Property	CL5000
BACnet Device ID	Device	Object identifier	R
BACnet Device ID	Device	Object name	R
BACnet Device ID	Device	Object type	R
BACnet Device ID	Device	System status	R/W
BACnet Device ID	Device	Vendor name	R
BACnet Device ID	Device	Vendor Identifier	R
BACnet Device ID	Device	Model name	R
BACnet Device ID	Device	Firmware revision	R
BACnet Device ID	Device	Application software version	R
BACnet Device ID	Device	Location	R/W
BACnet Device ID	Device	Description	R/W
BACnet Device ID	Device	Protocol version	R
BACnet Device ID	Device	Protocol services supported	R
BACnet Device ID	Device	Protocol object types supported	R
BACnet Device ID	Device	Protocol revision	R
BACnet Device ID	Device	Object list	R
BACnet Device ID	Device	Max APDU length supported	R
BACnet Device ID	Device	Segmentation supported	R
BACnet Device ID	Device	Local time	R
BACnet Device ID	Device	Local date	R
BACnet Device ID	Device	APDU time out	R/W
BACnet Device ID	Device	Number of APDU retries	R/W
BACnet Device ID	Device	Device address binding	R

Lonworks SNVT Types Point Map: CL5000				
Network Variable Name	SNVT Type	Description	Units	CL5000
nvoKWh_Del ¹	SNVT_count_inc_f	Energy delivered	kWh	R
nvoKWh_Rec ¹	SNVT_count_inc_f	Energy received	kWh	R
nvoKVarh_Del ¹	SNVT_count_inc_f	Reactive energy delivered	kVARh	R
nvoKVarh_Rec ¹	SNVT_count_inc_f	Reactive energy received	kVARh	R
nvoReal_Pwr	SNVT_count_inc_f	Real power	kW	R
nvoReact_Pwr	SNVT_count_inc_f	Reactive power	kVAR	R
nvoAppar_Pwr	SNVT_count_inc_f	Apparent power	kVA	R
nvoPwr_Fact	SNVT_pwr_fact_f	Power factor	% PF	R
nvoPeak_Dem	SNVT_count_inc_f	Peak demand	kW	R
nvoCurrent_Avg	SNVT_amp_f	Current average	Amps	R
nvoVolt_LN	SNVT_volt_f	Voltage line-neutral	Volts-N	R
nvoVolt_LL	SNVT_volt_f	Voltage line-line	Volts-L	R
nvoFrequency	SNVT_freq_f	Frequency	Hz	R
nvoPhase_Angle	SNVT_angle_f	Phase angle	Degree	R
nvoReal_Pwr_PhA	SNVT_count_inc_f	Real power, phase A	kW	R
nvoReal_Pwr_PhB	SNVT_count_inc_f	Real power, phase B	kW	R
nvoReal_Pwr_PhC	SNVT_count_inc_f	Real power, phase C	kW	R
nvoReact_Pwr_PhA	SNVT_count_inc_f	Reactive power, phase A	kVAR	R
nvoReact_Pwr_PhB	SNVT_count_inc_f	Reactive power, phase B	kVAR	R

CLASS 5000 METER

Lonworks SNVT Types Point Map: CL5000				
nvoReact_Pwr_PhC	SNVT_count_inc_f	Reactive power, phase C	kVAR	R
nvoAppar_Pwr_PhA	SNVT_count_inc_f	Apparent power, phase A	kVA	R
nvoAppar_Pwr_PhB	SNVT_count_inc_f	Apparent power, phase B	kVA	R
nvoAppar_Pwr_PhC	SNVT_count_inc_f	Apparent power, phase C	kVA	R
nvoPwr_Fact_PhA	SNVT_pwr_fact_f	Power factor, phase A	% PF	R
nvoPwr_Fact_PhB	SNVT_pwr_fact_f	Power factor, phase B	% PF	R
nvoPwr_Fact_PhC	SNVT_pwr_fact_f	Power factor, phase C	% PF	R
nvoCurrent_PhA	SNVT_amp_f	Current, phase A	Amps	R
nvoCurrent_PhB	SNVT_amp_f	Current, phase B	Amps	R
nvoCurrent_PhC	SNVT_amp_f	Current, phase C	Amps	R
nvoVolt_LN_PhA_N	SNVT_volt_f	Voltage, line to neutral, phase A-N	Volts-N	R
nvoVolt_LN_PhB_N	SNVT_volt_f	Voltage, line to neutral, phase B-N	Volts-N	R
nvoVolt_LN_PhC_N	SNVT_volt_f	Voltage, line to neutral, phase C-N	Volts-N	R
nvoVolt_LL_PhA_B	SNVT_volt_f	Voltage, line to line, phase A-B	Volts-L	R
nvoVolt_LL_PhB_C	SNVT_volt_f	Voltage, line to line, phase B-C	Volts-L	R
nvoVolt_LL_PhC_A	SNVT_volt_f	Voltage, line to line, phase C-A	Volts-L	R

Lonworks SNVT Types Point Map: CL5000				
nvoPhase_AngleA	SNVT_angle_f	Phase angle, phase A	Degree	R
nvoPhase_AngleB	SNVT_angle_f	Phase angle, phase B	Degree	R
nvoPhase_AngleC	SNVT_angle_f	Phase angle, phase C	Degree	R
nvoReserve_A	SNVT_count_f	Reserve A	No units	R
nvoReserve_B	SNVT_count_f	Reserve B	No units	R
nvoReserve_C	SNVT_count_f	Reserve C	No units	R
nvoExt_Input_1 ²	SNVT_count_f	External Input 1	Pulse	R
nvoExt_Input_2 ²	SNVT_count_f	External Input 2	Pulse	R

1. To clear single meter kWh/kVARh, select reset kW/kWh on the display menu of the meter. This function will also reset external inputs. Jumper J6 must be closed. Remove J6 after changes have been completed.
2. External inputs are standard on Class 5000 meters and optional on Class 3400 meters (Part of Expanded Feature Package). To clear external inputs, select reset kW/kWh on the display menu of the meter. This function will also reset kW/kVARh. Jumper J6 must be closed. Remove J6 after changes have been completed.

13.0 HIGH VOLTAGE METERING

kWh Meter Installation Instructions for Use with E-Mon Meters in High Voltage Applications

The E-Mon model # 12025HV kWh meter is designed to be used for monitoring high voltage (2400, 4160, 13200, etc) circuits, either “stand alone” or in an AMR application.

This meter is intended to be used with the appropriate high voltage Potential Transformers (PTs) and Current Transformers (CTs) supplied by others. The meter application is centered around a 120 VAC secondary output from the high voltage PTs and a 5 amp secondary output from the high voltage CTs.

Items addressed by this document include the installation of the 12025HV meter on high voltage circuits as well as the calculations to provide the correct meter multiplier based on the PT and CT sizes used on the high voltage conductors.

Installation should be performed by qualified personnel and only according to all applicable electrical codes.

High Voltage CTs (supplied by others) reduce the primary current (amps) to a directly proportional 0~5 amp secondary output. As an example, a 0~400 amp primary becomes a 0~5 amp proportional signal from the secondary output. In our application, the high voltage CT secondary is installed as a continuous “loop”, with a single conductor connected to both secondary terminals.

To convert the 0~5 amp signal to a 0~ 2 volt signal, E-Mon’s Current Sensors are installed on the CT secondary conductor. A set of 25 amp sensors is used in this application. These sensors have the high voltage CT secondary conductor passed through them five (5) times (see below) by looping the secondary conductor as shown in the drawing. The reason for this is so that the 5 amp secondary now appears to the current sensor as a 0~25 amp signal. This creates a conversion of the CT’s primary current to a directly proportional 0~ 2 volt signal which is utilized by the E-Mon meter. The example from the first paragraph has now become a 400 amp to 2 volt device, by this technique.

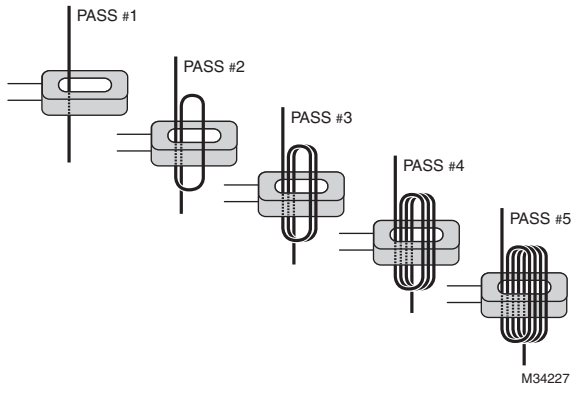

Fig. 24. High Voltage CTs.

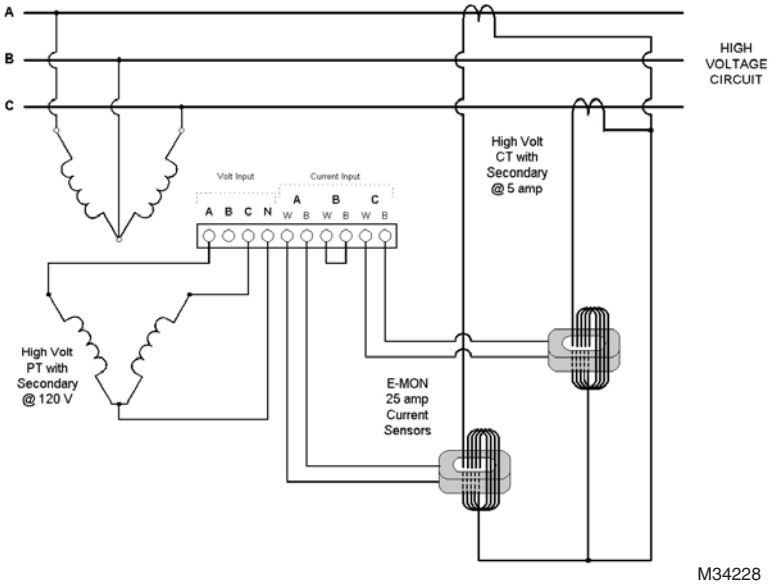

Fig. 25. Wiring Diagram For 3-wire High Voltage Circuits.

CLASS 5000 METER

This special high voltage meter installation shows the correct wiring procedure for 4-wire high voltage circuits. In this application, the 3 element meter connection is used on the secondary circuits of the user supplied high voltage PTs and CTs.

The E-Mon meter used in this application is the model 12025 HV.

Installation of these meters requires the use of three (3) current sensors mounted on the secondaries of the high voltage Current Transformers. See the drawing above for proper wiring. For correct operation, the meter must be installed correctly.

This special high voltage meter installation utilizes high voltage PTs (Potential Transformers) and CTs (Current Transformers) supplied by others. The E-Mon meter is installed using the secondary outputs of these devices.

High voltage PTs reduce the primary voltage (4160v, 13200v, etc.) to a Secondary output of 120v. This secondary is connected to the E-Mon meter voltage inputs as shown in the wiring diagram. High voltage CTs reduce the primary current (amps) to a directly proportional 0~5 amp output. As an example, a 0~400 amp primary becomes a 0~5 amp proportional signal from the secondary output. This allows much smaller wiring to be utilized in the meter hookup. The high voltage CT secondary is installed as a continuous "loop", with a single lead connected to both secondary terminals.

E-Mon meters accept a 0~2 volt signal from their Current Sensors. To convert the 0~5 amp signal, the Current Sensors are installed on the CT secondary lead. A set of 25 amp sensors is used in this application. These sensors have the high voltage CT secondary lead passed through them five (5) times by looping the wire as shown in the drawing. This allows a direct conversion of the CTs primary current to a directly proportional 0~2 volt signal, which is used by the meter.

Since there is a signal ratio introduced by the high voltage CTs and PTs, it will be necessary to multiply the number on the meter's display for a correct reading. The meter multiplier is calculated by using the CT ratio and the PT Ratio. [PTR x CTr / Number of Secondary Lead Passes Through Sensor]. The E-Mon 25 amp HV kWh meter with 5 wraps of the high voltage CT secondary will have its multiplier calculated by the formula shown below.

EXAMPLE:	CT = 400:5 = 80:1 (CTr = 80)
	PT = 4200:120 = 35:1 (PTR = 35)
	Wraps (Passes) = 5
	<i>METER MULTIPLIER</i> = PTR x (CTr/Wraps)
	35 x (80/5)
	35 x (16) = 560

14.0 METER LIMITED WARRANTY

Subject to the exclusions listed below, E-Mon will either repair or replace (at its option) any product that it manufactures and which contains a defect in material or workmanship.

The following exclusions apply:

1. This Limited Warranty is only effective for a period of (5) five years following the date of manufacture when installed in accordance with manufacturer's instructions by qualified personnel.
2. E-Mon must be notified of the defect within ninety (90) days after the defect becomes apparent or known.
3. Buyer's remedies shall be limited to repair or replacement of the product or component which failed to conform to E-Mon's express warranty set forth above.
4. Buyer shall be responsible for all freight costs and shall bear all risk of loss or damage to returned goods while in transit.
5. This Limited Warranty does not cover installation, removal, reinstallation, or labor costs, and excludes normal wear and tear. Buyer shall provide labor for the removal of the defective component or item and installation of its replacement at no charge to E-Mon.
6. This Limited Warranty does not cover any product if: (i) a product is altered or modified from its original manufactured condition, (ii) any repairs, alterations or other work has been performed by Buyer or others on such item, other than work performed with E-Mon's authorization and according to its approved procedures; (iii) the alleged defect is a result of abuse, misuse, improper maintenance, improper installation, accident or the negligence of any party; (iv) damaged as a result of events beyond E-Mon's control or other force majeure events or (v) used in conjunction with equipment, components, accessories, parts or materials not supplied or approved by E-Mon.
7. This Limited Warranty is limited to the obligation to repair or replace the manufactured product. This is the sole and exclusive remedy for any breach of warranty. IN NO EVENT SHALL E-MON BE LIABLE FOR ANY INDIRECT, INCIDENTAL, SPECIAL, CONSEQUENTIAL OR PUNITIVE DAMAGES (INCLUDING ANY DAMAGE FOR LOST PROFITS) ARISING OUT OF OR IN CONNECTION WITH THE FURNISHING OF PRODUCTS, PARTS OR SERVICES, OR THE PERFORMANCE, USE OF, OR INABILITY TO USE ANY PRODUCTS, PARTS OR SERVICES, SALE OF OR OTHERWISE, WHETHER BASED IN CONTRACT, WARRANTY, TORT, INCLUDING WITHOUT LIMITATION, NEGLIGENCE, OR ANY OTHER LEGAL OR EQUITABLE THEORY.
8. EXCEPT AS EXPRESSLY PROVIDED HEREIN, E-MON MAKES NO WARRANTY OF ANY KIND, EXPRESS OR IMPLIED WITH RESPECT TO ANY PRODUCTS, PARTS OR SERVICES PROVIDED BY E-MON INCLUDING, BUT NOT LIMITED TO, THE IMPLIED WARRANTIES OF MERCHANTABILITY AND FITNESS FOR A PARTICULAR PURPOSE. PRODUCTS OR COMPONENTS DISTRIBUTED, BUT NOT MANUFACTURED, BY E-MON ARE NOT WARRANTED BY E-MON AND BUYER MUST INSTEAD RELY ON THE REPRESENTATIONS AND WARRANTIES, IF ANY, PROVIDED DIRECTLY TO THE BUYER BY THE MANUFACTURER OF SUCH PRODUCT OR COMPONENT.

CLASS 5000 METER

CLASS 5000 METER

E-Mon

850 Town Center Drive
Langhorne, PA 19047

www.emon.com
info@emon.com

© U.S. Registered Trademark
© 2013 E-Mon
62-0392-03 JPG Rev. 04-13
Printed in United States

